

CORRUGATED STEEL SHEET T200

T200 BILKA corrugated sheet metal is manufactured in steel sheet, galvanized on both sides and protected with polyester. It is used for small inclination roofs and intermediate floors.

It is the ideal and economical solution for construction and rehabilitation of facilities intended for warehouses, shopping centers, production facilities, farms, silos, stables, sports centers, etc.

PRODUCTION SPECIFICATIONS:

- BILKA T200 corrugated steel is made with a nominal thickness between 0.75 – 2.5 mm, based on the construction requirements
- The standard length of the modules ranges from 0.500 m and 13.5 m. Execution of the modules with different lengths from the standard ones will be made after prior consultation with the technical specialist from BILKA
- BILKA produces corrugated sheet metal T200 in 13 colors, glossy options

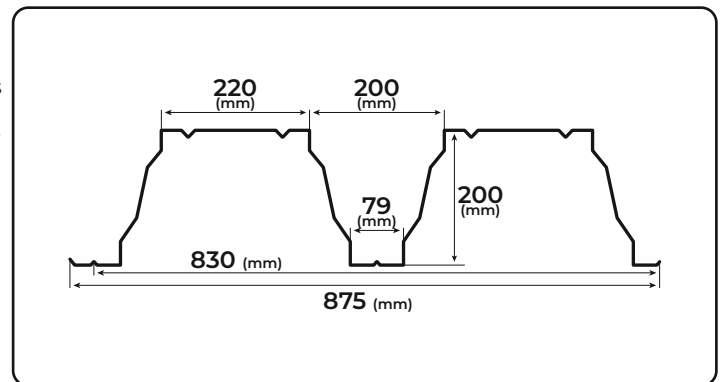

TECHNICAL CHARACTERISTICS	Material	Steel, galvanized sheet metal on both sides protected with polyester
	Standard thickness	0,75 mm - 2,5 mm
	Total width	875 mm
	Usable width	840 mm
	Total height	200 mm
	Weight on the surface	10,71 - 17,86 kg / mp
	Warranty	10-year warranty for colour characteristics and corrosion
	Estimated life cycle	60 years for the roof, withstands temperature fluctuations