

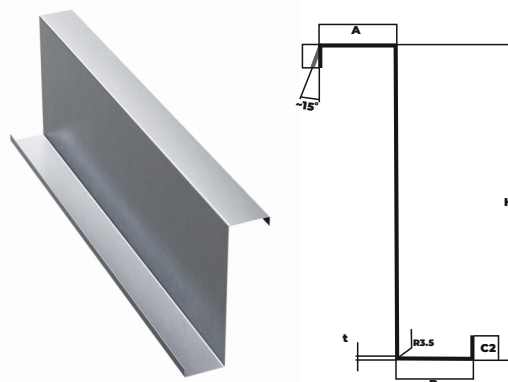

## VÝROBOK

# POZINKOVANÝ PROFIL Z



Kovové Z profily sú inováciou v oblasti kovových konštrukcií pre ľahké priemyselné haly. Používajú sa najmä ako na spojovacie prvky strechy, ale aj na vedľajších stavbách.

Tuhosť a pevnosť profilov umožňuje ich využitie napríklad na:

- ocelové konštrukčné prvky občianskej vybavenosti, v priemyselných a v poľnohospodárskych stavbách;
- alebo na druhotné prvky nosnej konštrukcie budov ako strešné panely a stenové nosníky.

TECHNICKÉ PARAMETRE	Výška prierezu	
	Hrúbka	1.5 - 3.5 mm
	Kvalita materiálu	S350GD+Z275
	Štandardné dĺžky rezu	250- 15000 mm * pre iné dĺžky kontaktujte technického zástupcu spoločnosti BILKA.

- Z profily sa dierujú podľa technického vrtacieho plánu. Dierovanie je možné na všetkých stranách a aj na pätke.
- Profily môžu mať rovnaké alebo rôzne strany;
- Všetky stavebné prvky sú spojené skrutkami pre rýchlu montáž na mieste stavby.

vzory dierovania	Typy dierovania		Dostupný priemer									
	Symbol	Forma	5	10	11	12	13	14	15	16	18	20
OKRÚHLÝ		22										
OVÁLNY		18x14 40x26	20x10 50x13	25x14 50x5	28x14	32x16	35x12	39x19	40x18	40x25		
ŠTVORCOVÝ		40x40										
OBDĹŽNIKOVÝ		16x24	28.5x18									
VIACERÉ KOMBINÁCIE												

TYP PROFILU	Rozmery prierezu							
	H (mm)	A(mm)	B (mm)	C1=C2 (mm)	t (mm)	t <sub>n</sub> (mm)	r (mm)	G(kg/ml)
Z100-1.5	100	47	40	18.0	1.46	1.5	3.5	2.48
Z100-2	100	47	40	18.0	1.96	2.0	3.5	3.25
Z120-1.5	120	47	40	18.0	1.46	1.5	3.5	2.72
Z120-2	120	47	40	18.0	1.96	2.0	3.5	3.56
Z120-2.5	120	60	53	22.0	2.46	2.5	3.5	5.05
Z140-1.5	140	47	40	18.0	1.46	1.5	3.5	2.96
Z140-1.5	140	66	59	22.0	1.46	1.5	3.5	3.47
Z140-2	140	47	40	18.5	1.96	2.0	3.5	3.89
Z140-2	140	66	59	22.0	1.96	2.0	3.5	4.58
Z140-2.5	140	66	59	22.0	2.46	2.5	3.5	5.65
Z140-3	140	66	59	22.0	2.96	3.0	3.5	6.71
Z140-3.5	140	66	59	22.0	3.46	3.5	3.5	7.72
Z150-1.5	150	47	40	18.0	1.46	1.5	3.5	3.07
Z150-1.5	150	66	59	22.0	1.46	1.5	3.5	3.59
Z150-2	150	47	40	18.5	1.96	2.0	3.5	4.05
Z150-2	150	66	59	22.0	1.96	2.0	3.5	4.73
Z150-2.5	150	47	40	20.0	2.46	2.5	3.5	5.04
Z150-2.5	150	66	59	22.0	2.46	2.5	3.5	5.85
Z150-3	150	66	59	22.0	2.96	3.0	3.5	6.95
Z150-3.5	150	66	59	22.0	3.46	3.5	3.5	8.00
Z160-1.5	160	47	40	18.0	1.46	1.5	3.5	3.19
Z160-1.5	160	66	59	22.0	1.46	1.5	3.5	3.71
Z160-2	160	47	40	18.5	1.96	2.0	3.5	4.21
Z160-2	160	66	59	22.0	1.96	2.0	3.5	4.89
Z160-2.5	160	47	40	20.0	2.46	2.5	3.5	5.24
Z160-2.5	160	66	59	22.0	2.46	2.5	3.5	6.06
Z160-3	160	66	59	22.0	2.96	3.0	3.5	7.18
Z160-3.5	160	66	59	22.0	3.46	3.5	3.5	8.27
Z180-1.5	180	60	53	20.0	1.46	1.5	3.5	3.78
Z180-1.5	180	66	59	22.0	1.46	1.5	3.5	3.94
Z180-2	180	60	53	22.0	1.96	2.0	3.5	5.04
Z180-2	180	66	59	22.0	1.96	2.0	3.5	5.20
Z180-2.5	180	60	53	23.0	2.46	2.5	3.5	6.26
Z180-2.5	180	66	59	22.0	2.46	2.5	3.5	6.44
Z180-3	180	60	53	23.0	2.96	3.0	3.5	7.42
Z180-3	180	66	59	22.0	2.96	3.0	3.5	7.65
Z180-3.5	180	60	53	23.0	3.46	3.5	3.5	8.54
Z180-3.5	180	66	59	22.0	3.46	3.5	3.5	8.82
Z200-1.5	200	67	59	23.5	1.46	1.5	3.5	4.25
Z200-1.5	200	73	65	24.0	1.46	1.5	3.5	4.38
Z200-2	200	67	59	24.0	1.96	2.0	3.5	5.62
Z200-2	200	73	65	24.0	1.96	2.0	3.5	5.79
Z200-2.5	200	67	59	26.0	2.46	2.5	3.5	7.03
Z200-2.5	200	73	65	26.0	2.46	2.5	3.5	7.24
Z200-3	200	67	59	26.0	2.96	3.0	3.5	8.34
Z200-3	200	73	65	26.0	2.96	3.0	3.5	8.62
Z200-3.5	200	67	59	26.0	3.46	3.5	3.5	9.62
Z200-3.5	200	73	65	26.0	3.46	3.5	3.5	9.95

TYP PROFILU	Rozmery prierezu							
	H (mm)	A(mm)	B (mm)	C1=C2 (mm)	t (mm)	t <sub>n</sub> (mm)	r (mm)	G(kg/ml)
Z250-1.5	250	67	59	23.5	1.46	1.5	3.5	4.84
Z250-1.5	250	73	65	24.0	1.46	1.5	3.5	4.97
Z250-2	250	67	59	24.0	1.96	2.0	3.5	6.41
Z250-2	250	73	65	24.0	1.96	2.0	3.5	6.57
Z250-2.5	250	67	59	26.0	2.46	2.5	3.5	8.01
Z250-2.5	250	73	65	26.0	2.46	2.5	3.5	8.22
Z250-3	250	67	59	26.0	2.96	3.0	3.5	9.51
Z250-3	250	73	65	26.0	2.96	3.0	3.5	9.80
Z250-3.5	250	67	59	26.0	3.46	3.5	3.5	10.99
Z250-3.5	250	73	65	26.0	3.46	3.5	3.5	11.32
Z300-1.5	300	78	70	23.5	1.46	1.5	3.5	5.69
Z300-2	300	78	70	24.0	1.96	2.0	3.5	7.54
Z300-2	300	89	81	24.0	1.96	2.0	3.5	7.86
Z300-2.5	300	78	70	26.0	2.46	2.5	3.5	9.42
Z300-2.5	300	89	81	24.0	2.46	2.5	3.5	9.75
Z300-3	300	78	70	26.0	2.96	3.0	3.5	11.21
Z300-3	300	89	81	26.0	2.96	3.0	3.5	11.73
Z300-3.5	300	78	70	26.0	3.46	3.5	3.5	12.97
Z300-3.5	300	89	81	26.0	3.46	3.5	3.5	13.57
Z350-1.5	350	78	70	23.0	1.46	1.5	3.5	6.26
Z350-2	350	78	70	23.0	1.96	2.0	3.5	8.29
Z350-2	350	100	92	25.0	1.96	2.0	3.5	9.02
Z350-2.5	350	78	70	25.0	2.46	2.5	3.5	10.36
Z350-2.5	350	100	92	26.0	2.46	2.5	3.5	11.25
Z350-3	350	78	70	25.0	2.96	3.0	3.5	12.34
Z350-3	350	100	92	27.0	2.96	3.0	3.5	13.47
Z350-3.5	350	78	70	25.0	3.46	3.5	3.5	14.29
Z350-3.5	350	100	92	28.0	3.46	3.5	3.5	15.66
Z400-1.5	400	89	81	24.0	1.46	1.5	3.5	7.14
Z400-2	400	89	81	25.0	1.96	2.0	3.5	9.48
Z400-2	400	100	92	30.0	1.96	2.0	3.5	9.96
Z400-2.5	400	89	81	26.0	2.46	2.5	3.5	11.81
Z400-2.5	400	100	92	30.0	2.46	2.5	3.5	12.38
Z400-3	400	89	81	26.0	2.96	3.0	3.5	14.08
Z400-3	400	100	92	30.0	2.96	3.0	3.5	14.79
Z400-3.5	400	89	81	26.0	3.46	3.5	3.5	16.32
Z400-3.5	400	100	92	30.0	3.46	3.5	3.5	17.14

TYP PROFILU	Geometrické vlastnosti nespracovaného rezu									
	A (mm <sup>2</sup> )	Y <sub>c</sub> (mm)	Z <sub>G1</sub> (mm)	Z <sub>G2</sub> (mm)	I <sub>y</sub> (cm <sup>4</sup> )	W <sub>y1</sub> (cm <sup>3</sup> )	W <sub>y2</sub> (cm <sup>3</sup> )	I <sub>z</sub> (cm <sup>4</sup> )	i <sub>y</sub> (cm)	i <sub>z</sub> (cm)
Z100-1.5	308.1	40.5	47.6	51.0	45.07	9.47	8.85	14.22	3.92	2.20
Z100-2	405.7	40.0	47.4	50.7	59.63	12.58	11.76	19.12	3.89	2.18
Z120-1.5	337.3	40.3	57.5	61.1	69.32	12.06	11.34	14.23	4.64	2.10
Z120-2	444.9	39.8	57.2	60.9	92.01	16.08	15.12	19.14	4.61	2.08
Z120-2.5	548.6	39.4	57.0	60.6	114.04	20.01	18.81	24.03	4.58	2.06
Z140-1.5	366.5	40.1	67.3	71.2	105.36	15.66	14.80	14.74	5.35	2.04
Z140-1.5	430.7	59.4	67.6	71.6	135.68	20.07	18.94	43.25	5.57	3.17
Z140-2	486.1	39.6	67.1	70.9	138.67	20.67	19.56	20.26	5.32	2.02
Z140-2	571.34	58.9	67.4	70.6	176.52	26.19	25.00	56.14	5.54	3.13
Z140-2.5	708.5	58.4	67.1	70.4	214.26	31.93	30.43	67.60	5.52	3.09
Z140-3	843.6	57.9	66.8	70.2	261.49	39.14	37.25	81.42	5.49	3.06
Z140-3.5	972.3	57.4	66.6	69.9	299.41	44.96	42.83	92.14	5.46	3.03
Z150-1.5	381.1	40.1	72.3	76.3	117.93	16.32	15.45	14.24	5.69	1.98
Z150-1.5	445.3	59.3	72.6	75.9	161.55	22.25	21.28	44.62	5.94	3.11
Z150-2	505.7	39.6	72.0	76.1	157.05	21.80	20.65	19.15	5.66	1.98
Z150-2	590.9	58.8	72.3	75.7	211.64	29.27	27.96	57.41	5.91	3.08
Z150-2.5	632.2	39.2	71.8	75.8	195.31	27.21	25.76	24.05	5.63	1.96
Z150-2.5	733.1	58.3	72.0	75.5	260.14	36.13	34.46	69.32	5.88	3.04
Z150-3	873.2	57.8	71.8	75.2	307.58	42.84	40.90	81.64	5.86	3.01
Z150-3.5	1006.9	57.3	71.5	75.0	352.35	49.28	46.98	92.67	5.84	2.98
Z160-1.5	395.7	39.9	77.2	81.3	147.64	19.12	18.16	15.94	6.04	1.99
Z160-1.5	459.9	59.3	77.5	81.0	185.46	23.93	22.90	43.45	6.29	3.04
Z160-2	525.3	39.5	76.9	81.1	194.67	25.31	24.00	20.64	6.01	1.95
Z160-2	610.5	58.8	77.2	80.8	240.87	31.20	29.81	56.77	6.27	3.01
Z160-2.5	656.8	39.0	76.7	80.8	240.32	31.33	29.74	25.43	5.98	1.93
Z160-2.5	760.1	58.3	76.9	80.6	293.41	38.15	36.40	67.42	6.24	2.99
Z160-3	902.8	57.9	76.7	80.3	358.42	46.73	44.63	81.17	6.22	2.96
Z160-3.5	1041.5	57.3	76.5	80.0	411.59	53.80	51.45	92.15	6.20	2.94
Z180-1.5	468.7	53.2	87.4	91.2	227.69	26.05	24.97	33.10	6.99	2.66
Z180-1.5	489.1	59.2	87.4	91.1	243.58	27.87	26.74	44.36	7.01	2.97
Z180-2	629.2	52.7	87.2	90.9	304.53	34.94	33.49	44.64	6.96	2.67
Z180-2	649.7	58.7	87.1	90.9	317.69	36.47	34.95	56.68	6.98	2.93
Z180-2.5	784.7	52.2	86.9	90.7	380.44	43.77	41.95	56.20	6.94	2.67
Z180-2.5	806.9	58.2	86.9	90.6	387.62	44.61	42.78	67.41	6.95	2.91
Z180-3	932.4	51.8	86.6	90.4	447.10	51.66	49.46	64.92	6.91	2.65
Z180-3	962.0	57.7	86.6	90.4	473.64	54.69	52.39	81.95	6.93	2.88
Z180-3.5	1076.1	51.3	86.3	90.2	514.67	59.64	57.06	72.94	6.89	2.63
Z180-3.5	1110.7	57.1	86.4	90.1	543.67	62.92	60.34	92.46	6.91	2.85
Z200-1.5	527.1	59.1	97.5	101.1	311.74	31.99	30.83	42.99	7.71	2.93
Z200-1.5	543.1	65.2	97.5	101.1	330.74	33.94	32.71	57.99	7.84	3.29
Z200-2	701.7	58.7	97.2	100.9	415.59	42.75	41.20	57.63	7.68	2.91
Z200-2	722.3	64.8	97.2	100.9	442.59	45.53	43.87	78.21	7.82	3.27
Z200-2.5	880.7	58.3	97.0	100.6	520.19	53.64	51.70	75.26	7.65	2.89
Z200-2.5	907.7	64.3	97.0	100.6	553.19	57.04	54.98	98.50	7.79	3.26
Z200-3	1047.8	58.0	96.3	100.7	624.46	64.85	62.01	91.64	7.63	2.88
Z200-3	1083.4	63.9	96.4	100.6	659.46	68.41	65.55	116.32	7.75	3.24
Z200-3.5	1211.0	57.9	96.0	100.5	718.44	74.84	71.49	104.58	7.62	2.88
Z200-3.5	1252.5	63.4	96.1	100.4	759.34	79.02	75.63	132.60	7.68	3.20

TYP PROFILU	Geometrické vlastnosti nespracovaného rezu									
	A (mm <sup>2</sup> )	y <sub>c</sub> (mm)	Z <sub>G1</sub> (mm)	Z <sub>G2</sub> (mm)	I <sub>y</sub> (cm <sup>4</sup> )	W <sub>y1</sub> (cm <sup>3</sup> )	W <sub>y2</sub> (cm <sup>3</sup> )	I <sub>z</sub> (cm <sup>4</sup> )	i <sub>y</sub> (cm)	i <sub>z</sub> (cm)
Z250-1.5	600.1	58.9	122.1	126.4	542.25	44.41	42.90	45.26	9.42	2.75
Z250-1.5	616.1	65.0	122.3	126.3	558.87	45.71	44.24	58.01	9.58	3.08
Z250-2	799.7	58.4	121.8	126.2	716.34	58.81	56.76	59.46	9.39	2.73
Z250-2	820.3	64.6	122.0	126.1	749.06	61.39	59.42	78.23	9.56	3.09
Z250-2.5	1003.7	57.9	121.6	125.9	895.65	73.66	71.16	77.15	9.37	2.71
Z250-2.5	1030.7	64.1	121.8	125.8	937.78	77.01	74.53	98.53	9.56	3.06
Z250-3	1195.8	57.5	121.1	125.9	1,068.41	88.23	84.86	91.45	9.35	2.70
Z250-3	1231.4	63.7	121.4	125.6	1,123.48	92.54	89.45	116.35	9.53	3.04
Z250-3.5	1384.0	57.3	120.8	125.7	1,230.94	101.90	97.93	104.75	9.31	2.69
Z250-3.5	1425.5	63.4	120.9	125.6	1,294.31	107.06	103.05	132.98	9.50	3.02
Z300-1.5	705.2	69.9	147.1	151.4	916.73	62.32	60.54	69.26	11.28	3.12
Z300-2	940.8	69.4	146.8	151.2	1,213.34	82.65	80.26	90.06	11.26	3.09
Z300-2	981.0	80.5	147.0	151.1	1,287.70	87.60	85.22	131.55	11.51	3.68
Z300-2.5	1180.8	68.9	146.6	150.9	1,516.58	103.45	100.50	115.21	11.24	3.07
Z300-2.5	1222.6	80.1	146.8	150.8	1,613.83	109.97	106.99	165.91	11.49	3.68
Z300-3	1404.2	68.5	146.1	150.9	1,810.64	123.93	119.99	139.85	11.21	3.06
Z300-3	1474.1	79.6	146.5	150.6	1,944.46	132.72	129.12	201.07	11.47	3.69
Z300-3.5	1647.3	68.2	145.7	150.8	2,089.64	143.42	138.57	158.64	11.19	3.05
Z300-3.5	1709.2	79.2	145.9	150.6	2,258.83	154.85	149.99	229.64	11.43	3.66
Z350-1.5	776.7	69.7	171.9	176.6	1,326.93	77.19	75.14	69.67	12.93	2.95
Z350-2	1034.9	69.2	171.7	176.3	1,752.81	102.09	99.42	91.23	12.89	2.92
Z350-2	1126.0	92.5	172.0	176.1	2,005.22	116.61	113.85	189.59	13.39	4.12
Z350-2.5	1298.9	68.7	171.5	176.0	2,192.36	127.83	124.54	113.72	12.85	2.90
Z350-2.5	1409.6	92.0	171.7	175.9	2,514.45	146.43	142.97	239.14	13.37	4.13
Z350-3	1551.0	68.3	170.9	176.1	2,617.15	153.14	148.62	136.75	12.84	2.89
Z350-3	1693.1	91.5	171.5	175.6	3,031.40	176.78	172.61	289.89	13.35	4.13
Z350-3.5	1799.2	67.9	170.6	175.9	3,039.55	178.17	172.80	159.66	12.81	2.88
Z350-3.5	1972.2	91.0	171.2	175.4	3,548.70	207.25	202.36	342.05	13.34	4.14
Z400-1.5	884.8	80.7	196.9	201.6	1,979.21	100.52	98.18	99.72	14.79	3.35
Z400-2	1183.8	80.2	196.7	201.3	2,629.57	133.68	130.63	133.54	14.76	3.34
Z400-2	1243.6	92.4	196.9	201.2	2,754.50	139.93	136.88	189.61	15.07	3.95
Z400-2.5	1480.9	79.7	196.4	201.1	3,273.79	166.69	162.79	165.83	14.74	3.32
Z400-2.5	1552.3	91.9	196.6	201.0	3,455.69	175.76	171.93	239.16	15.05	3.96
Z400-3	1770.1	79.5	195.9	201.1	3,910.24	199.60	194.44	201.65	14.71	3.30
Z400-3	1858.9	91.4	196.4	200.7	4,168.25	212.27	207.65	289.91	15.04	3.96
Z400-3.5	2055.2	79.2	195.6	200.9	4,523.47	231.26	225.16	229.03	14.69	3.29
Z400-3.5	2159.0	90.9	196.1	200.5	4,880.04	248.83	243.42	341.49	15.02	3.97

TYP PROFILU	Odolnosť na základe nespracovaného rezu	
	Natahovanie N (kN)	Ohýbanie M (kNm)
Z100-1.5	107.82	3.10
Z100-2	142.00	4.12
Z120-1.5	118.04	3.97
Z120-2	155.72	5.29
Z120-2.5	192.00	6.58
Z140-1.5	128.26	5.18
Z140-1.5	150.75	6.63
Z140-2	170.13	6.85
Z140-2	199.97	8.75
Z140-2.5	247.97	10.65
Z140-3	295.26	13.04
Z140-3.5	340.29	14.99
Z150-1.5	133.37	5.41
Z150-1.5	155.86	7.45
Z150-2	176.99	7.23
Z150-2	206.83	9.79
Z150-2.5	221.28	9.02
Z150-2.5	256.58	12.06
Z150-3	305.62	14.32
Z150-3.5	352.40	16.44
Z160-1.5	138.48	6.36
Z160-1.5	160.97	8.01
Z160-2	183.85	8.40
Z160-2	213.69	10.43
Z160-2.5	229.89	10.41
Z160-2.5	266.05	12.74
Z160-3	315.98	15.62
Z160-3.5	364.51	18.01
Z180-1.5	164.03	8.74
Z180-1.5	171.19	9.36
Z180-2	220.21	11.72
Z180-2	227.41	12.23
Z180-2.5	274.66	14.68
Z180-2.5	282.41	14.97
Z180-3	326.34	17.31
Z180-3	336.70	18.34
Z180-3.5	376.62	19.97
C180-3.5	388.73	21.12
Z200-1.5	184.47	10.79
Z200-1.5	190.09	11.45
Z200-2	245.59	14.42
Z200-2	252.79	15.36
Z200-2.5	308.24	18.09
Z200-2.5	317.71	19.24
Z200-3	366.74	21.70
Z200-3	379.18	22.94
Z200-3.5	423.85	25.02
Z200-3.5	438.38	26.47

TYP PROFILU	Odolnosť na základe nespracovaného rezu	
	Natahovanie N (kN)	Ohýbanie M (kNm)
Z250-1.5	210.02	15.01
Z250-1.5	215.64	15.48
Z250-2	279.89	19.87
Z250-2	287.09	20.80
Z250-2.5	351.29	24.91
Z250-2.5	360.76	26.09
Z250-3	418.54	29.70
Z250-3	430.98	31.31
Z250-3.5	484.40	34.27
Z250-3.5	498.93	36.07
Z300-1.5	246.81	21.19
Z300-2	329.28	28.09
Z300-2	343.34	29.83
Z300-2.5	413.28	35.18
Z300-2.5	427.92	37.45
Z300-3	491.47	42.00
Z300-3	515.93	45.19
Z300-3.5	576.55	48.50
Z300-3.5	598.23	52.50
Z350-1.5	271.85	26.30
Z350-2	362.21	34.80
Z350-2	394.11	39.85
Z350-2.5	454.61	43.59
Z350-2.5	493.35	50.04
Z350-3	542.86	52.02
Z350-3	592.59	60.41
Z350-3.5	629.72	60.48
Z350-3.5	690.27	70.83
Z400-1.5	309.67	34.36
Z400-2	414.34	45.72
Z400-2	435.27	47.91
Z400-2.5	518.32	56.98
Z400-2.5	543.29	60.18
Z400-3	619.53	68.05
Z400-3	650.61	72.68
Z400-3.5	719.33	78.81
Z400-3.5	755.66	85.20